

# RAK1904 WisBlock 3-axis Acceleration Sensor Datasheet

## Overview

### Description

The RAK1904 WisBlock 3-axis Acceleration Sensor, part of the RAK Wireless Wisblock series, is an ultra-low-power high-performance three-axis linear accelerometer with a digital I2C interface. The device features ultra-low-power operational modes that allow advanced power saving and smart embedded functions. The accelerometer of the RAK1904 module can be dynamically configured to work in the scales of  $\pm 2g/\pm 4g/\pm 8g/\pm 16g$ , and is capable of measuring accelerations with output data rates from 1 Hz to 5.3 kHz.

### Features

- **User selectable scales:**  $\pm 2g/\pm 4g/\pm 8g/\pm 16g$
- **Data acquisition rates:** from 1 Hz to 5.3 kHz
- **Module size:** 10 x 10 mm

## Specifications

### Overview

### Mounting

The RAK1904 module can be mounted on the slots: A, B, C, or D of the WisBase board. Figure 1 shows the mounting mechanism of the RAK1904 on a WisBase module, such as the RAK5005-O.

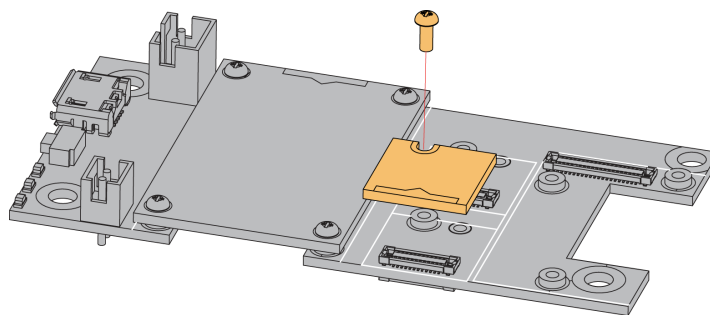

Figure 1: RAK1904 WisBlock Sensor Mounting

## Hardware

### Chipset

Vendor	Part number
TI	OPT3001DNPR

### Pin Definition

The RAK1904 WisBlock 3-axis Acceleration Sensor comprises a standard WisIO connector. This WisIO connector allows the RAK1904 module to be mounted on a WisBlock baseboard, such as, RAK5005-O. The pin order of the

connector and the definition of the pinout are shown in Figure 2. Note, only the I2C related pins, interrupt pins, VDD, and GND are connected to this module.

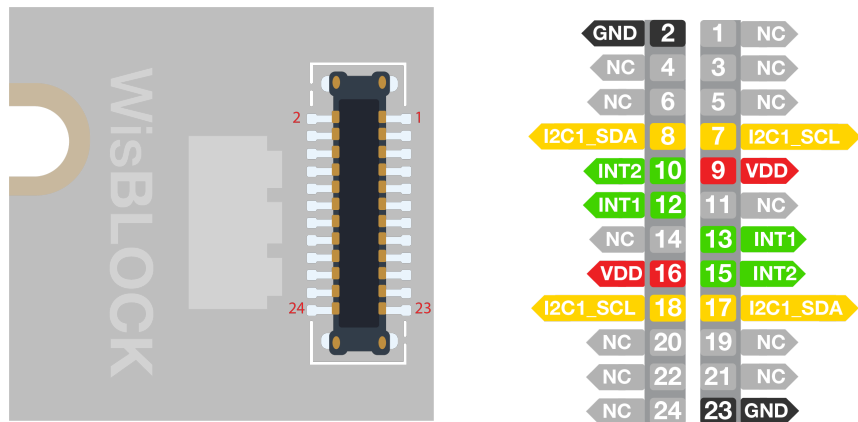

Figure 2: RAK1904 WisBlock Sensor Pinout Diagram

**NOTE:**

Pins 10, 12, 13, and 15 are connected to the interrupt pins of LIS3DH, please refer to the datasheet of LIS3DH for details.

## Sensors

### Acceleration Sensor

Symbol	Parameter	Test Condition	Min.	Typ.	Max.	Unit
FS	Measurment Range	FS bit set to 00		±2.0		g
		FS bit set to 01		±4.0		g
		FS bit set to 10		±8.0		g
		FS bit set to 10		±16.0		g
So	Sensitivity	FS bit set to 00 High-resolution mode		1		mg/digit
		FS bit set to 00 Normal mode		4		mg/digit
		FS bit set to 00 Low-power mode		16		mg/digit
		FS bit set to 01 High-resolution mode		2		mg/digit
		FS bit set to 01 Normal mode		8		mg/digit
		FS bit set to 01 Low-power mode		32		mg/digit
		FS bit set to 10 High-resolution mode		4		mg/digit
		FS bit set to 10 Normal mode		16		mg/digit
		FS bit set to 10 Low-power mode		64		mg/digit
		FS bit set to 11 High-resolution mode		12		mg/digit
		FS bit set to 11 Normal mode		48		mg/digit
		FS bit set to 11 Low-power mode		192		mg/digit

## Electrical Characteristics

### Recommended Operating Conditions

Symbol	Description	Min.	Nom.	Max.	Unit
$V_{DD}$	Power supply for the module	1.71	2.5	3.6	V
$I_{pdn}$	Power-down current	-	0.5	-	uA
$I_{DD}$	@50Hz	-	11	-	uA
$I_{DD}$	@1Hz	-	2	-	uA

## Mechanical Characteristics

### Board Dimensions

Figure 3 shows the dimensions and the mechanic drawing of the RAK1904 module.

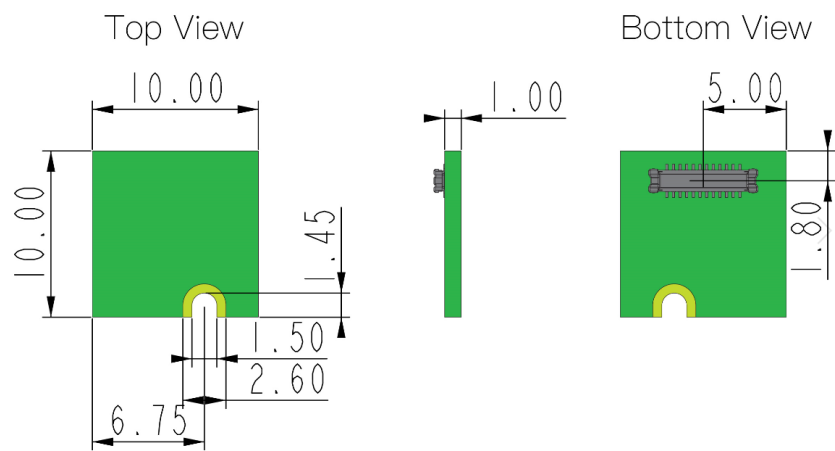

Figure 3: RAK1904 WisBlock Sensor Mechanic Drawing

### WisConnector PCB Layout

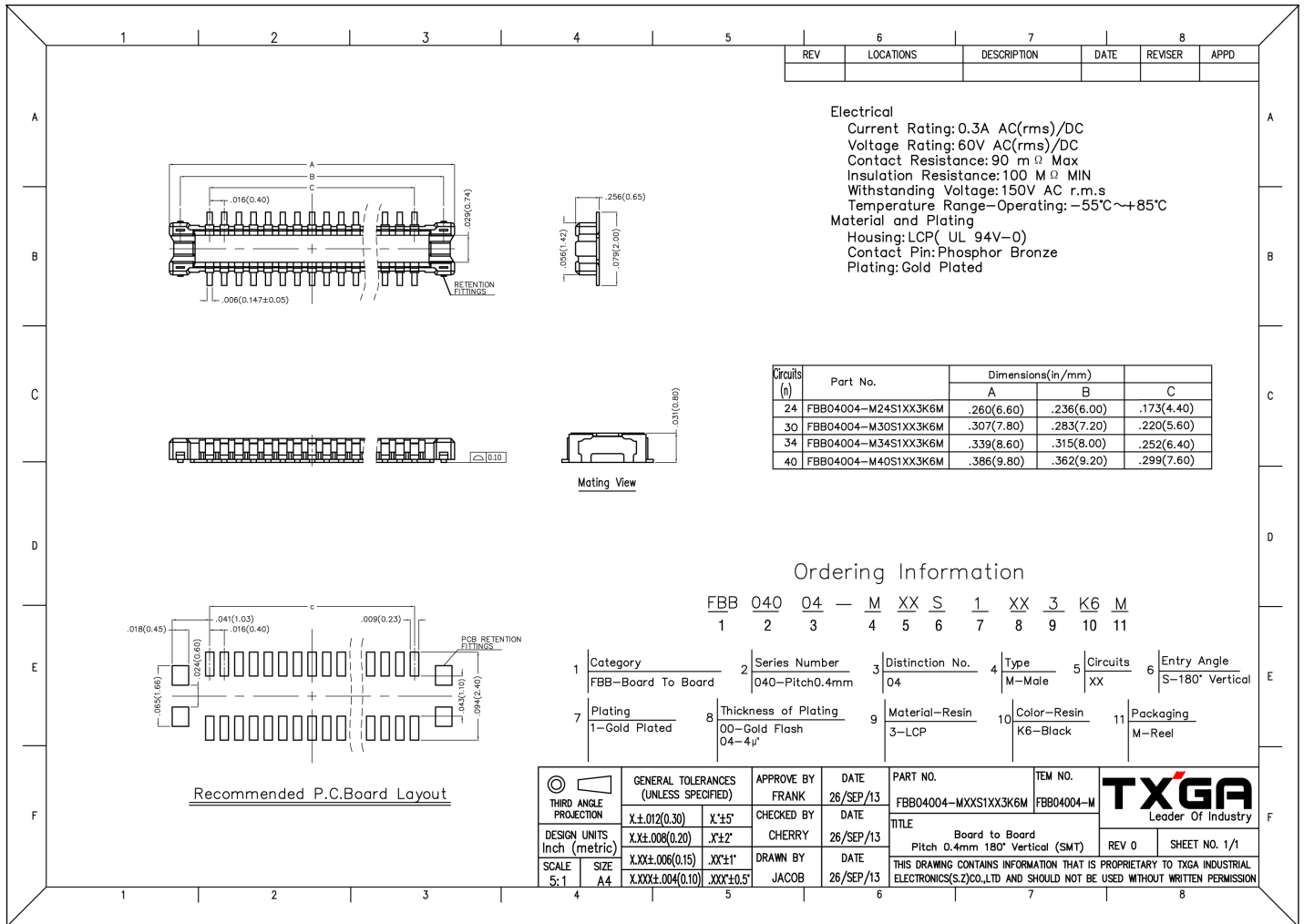

Figure 4: WisConnector PCB footprint and recommendations

## Schematic Diagram

The Figure 5 shows the schematic of the RAK1904 module.

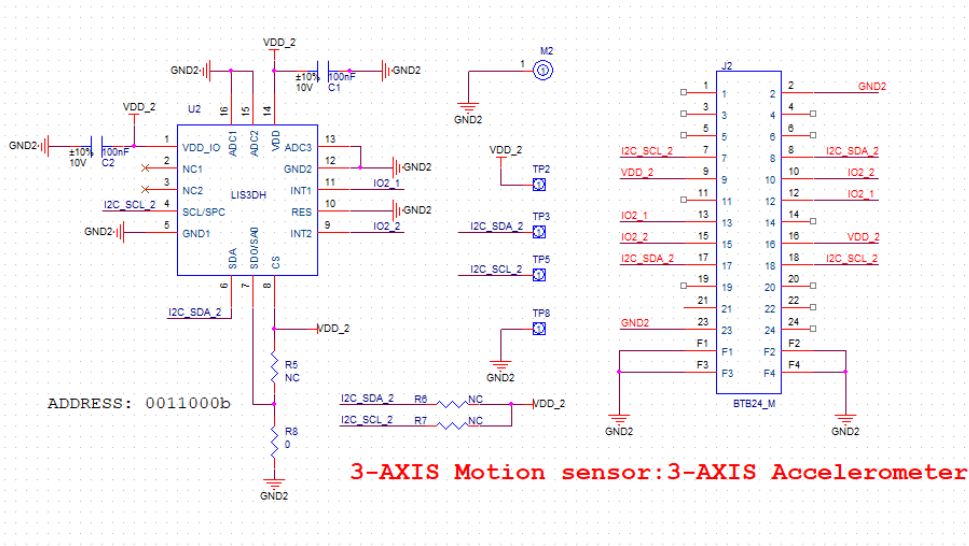

Figure 5: RAK1904 WisBlock Sensor schematics